

# Constant hangers Type 11

**Constant hangers**  
type 11 C3 19 to 11 96 15  
Serialized standard design,  
delivery from stock.

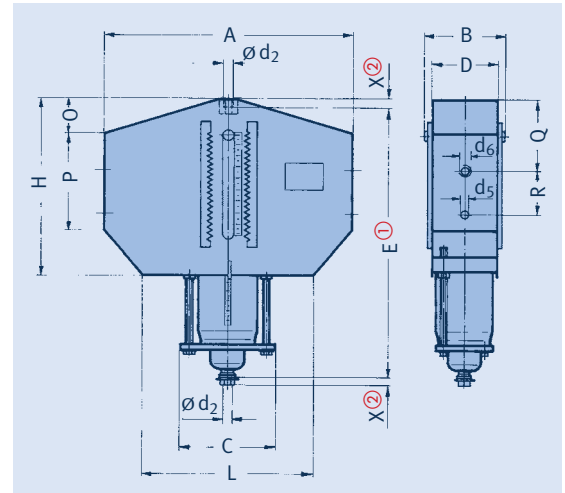

① Dimension E for upper blocking position, in other blocking positions dimension E lengthens accordingly.

② X = minimum engagement depth. At the lower connection, maximum engagement depth = X + 300mm.

type	A	B	C	D	d <sub>2</sub>	d <sub>5</sub>	d <sub>6</sub>	E <sup>①</sup>	H	L	O	P	Q	R	X <sup>②</sup>	weight [kg]
11 C3 19	350	130	150	105	M10	9	Ø 9	530	455	250	40	265	240	43	15	14
11 D2 19	300	110	155	86	M10	11	Ø11	350	250	230	0	195	125	43	15	10
11 D3 19	410	130	170	106	M10	11	Ø11	545	445	260	45	280	255	43	15	19
11 12 15	385	130	140	106	M12	12	M10	375	265	285	25	135	40	86	15	15
11 13 15	415	130	140	106	M12	12	M10	645	445	285	20	270	165	86	15	25
11 14 15	435	130	140	106	M12	12	M10	935	615	285	25	325	225	86	15	34
11 15 15	465	135	150	108	M12	12	M10	1225	795	295	25	450	350	86	15	52
11 22 15	445	160	180	132	M12	12	M10	385	270	350	20	140	45	86	15	21
11 23 15	460	160	185	132	M12	12	M10	650	455	360	45	270	195	86	15	35
11 24 15	480	160	185	132	M12	12	M10	945	635	360	45	320	245	86	15	48
11 25 15	530	165	195	136	M12	12	M10	1215	810	370	25	460	365	86	15	75
11 32 15	445	170	190	132	M16	12	M10	390	275	360	10	165	30	112	20	27
11 33 15	490	170	190	132	M16	12	M10	675	470	360	70	260	180	110	20	43
11 34 13	545	185	210	150	M16	12	M10	960	645	370	40	370	260	110	20	66
11 35 13	615	190	220	155	M16	12	M10	1240	820	370	40	465	360	110	20	105
11 42 15	500	185	220	150	M20	16	M12	440	315	400	25	260	135	105	25	44
11 43 15	570	185	220	150	M20	16	M12	740	495	410	110	250	210	105	25	66
11 44 13	610	185	220	150	M20	16	M12	1040	675	410	55	370	275	105	25	86
11 45 13	665	190	240	155	M20	16	M12	1285	855	420	65	540	455	105	25	145
11 52 15	590	230	270	190	M24	20	M16	470	345	490	30	210	70	115	30	73
11 53 15	710	230	270	190	M24	20	M16	770	515	490	105	285	215	126	30	115
11 54 15	745	230	285	190	M24	20	M16	1105	705	490	75	410	310	126	30	159
11 55 15	845	230	285	190	M24	20	M16	1405	880	490	60	530	415	135	30	212
11 62 15	725	275	335	230	M30	25	M16	555	420	580	40	240	85	145	35	134
11 63 15	815	275	335	230	M30	25	M16	900	565	580	160	300	260	145	35	183
11 64 15	845	275	345	230	M30	25	M16	1285	750	600	150	355	310	149	35	264
11 65 15	885	275	345	230	M30	25	M16	1630	925	600	120	460	380	149	35	337
11 66 15	1145	280	345	232	M30	25	M16	2030	1330	600	155	650	600	149	35	495
11 72 15	780	300	380	252	M36	35	M20	610	455	650	50	285	110	170	45	195
11 73 15	850	300	380	252	M36	35	M20	945	635	650	140	300	205	170	45	262
11 74 15	1000	300	400	252	M36	35	M20	1375	785	650	195	400	360	179	45	378
11 75 15	1160	305	400	256	M36	35	M20	1710	975	660	65	665	490	184	45	550
11 76 15	1275	305	400	256	M36	35	M20	2150	1425	660	210	710	675	184	45	690
11 82 15	815	320	390	256	M42	35	M20	705	585	650	50	330	115	200	50	263
11 83 15	945	320	390	256	M42	35	M20	1140	715	650	215	340	280	200	50	364
11 84 15	1110	320	400	256	M42	35	M20	1645	925	670	305	390	420	200	50	509
11 85 15	1200	320	420	256	M42	35	M20	2085	1115	690	125	740	595	200	50	731
11 86 15	1260	325	420	260	M42	35	M20	2585	1625	690	250	850	825	200	50	965
11 92 15	865	350	435	276	M48	35	M24	760	630	750	50	350	135	195	60	336
11 93 15	1095	350	435	276	M48	35	M24	1190	785	750	250	355	325	195	60	475
11 94 15	1240	350	455	276	M48	35	M24	1735	960	770	380	380	480	195	60	677
11 95 15	1255	355	455	280	M48	35	M24	2160	1090	770	250	585	570	195	60	862
11 96 15	1305	355	455	280	M48	35	M24	2700	1620	770	290	800	820	195	60	1130

**Order details:**  
constant hanger  
type 11 ...  
marking: ...  
calibration load: ...kN  
travel: ...mm up/down  
blocking position  
(as required): ...mm