

Constant supports Type 19

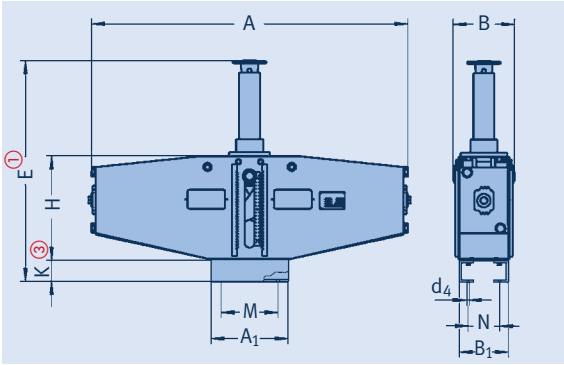

**Constant supports
type 19 D3 17 to 19 93 17**
Standard design,
delivery from stock.

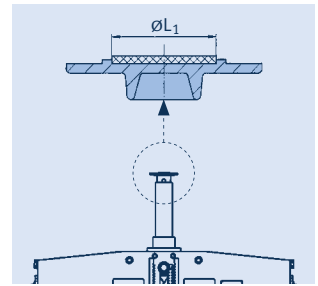

Load plate with integrated slide plate. This must be considered in the selection of clamp bases.

type ^②	min. load [kN]	max. load [kN]	travel	A	A ₁	B	B ₁	d ₄	E ^①	H	K ^③	M	N	weight [kg]
19 D3 17	0.21	0.51	300	973	245	205	163	14.5	913	430	80	185	103	60
19 D1 27	0.21	0.72	75	610	245	205	163	14.5	490	234	80	185	103	36
19 D2 27	0.21	0.72	150	664	245	205	163	14.5	600	270	80	185	103	41
19 D3 27	0.37	0.72	300	973	245	205	163	14.5	913	430	80	185	103	60
19 11 27	0.54	1.71	75	610	245	205	163	14.5	490	234	80	185	103	37
19 12 27	0.54	1.71	150	664	245	205	163	14.5	600	270	80	185	103	42
19 13 27	0.54	1.71	300	973	245	205	163	14.5	913	430	80	185	103	65
19 21 17	1.25	3.0	75	610	245	205	163	14.5	490	234	80	185	103	37
19 22 17	1.25	3.0	150	664	245	205	163	14.5	600	270	80	185	103	46
19 23 17	1.25	3.0	300	973	245	205	163	14.5	913	430	80	185	103	65
19 21 27	2.2	4.0	75	610	245	205	163	14.5	490	234	80	185	103	38
19 22 27	2.2	4.0	150	664	245	205	163	14.5	600	270	80	185	103	46
19 23 27	2.2	4.0	300	973	245	205	163	14.5	913	430	80	185	103	66
19 31 17	2.8	5.15	75	652	245	205	163	14.5	499	244	80	185	103	42
19 32 17	2.8	5.15	150	837	300	233	189	18.5	639	293	100	210	124	83
19 33 17	2.8	5.15	300	1099	300	233	189	18.5	969	440	100	210	124	110
19 31 27	3.8	6.8	75	652	245	205	163	14.5	499	244	80	185	103	43
19 32 27	3.8	6.8	150	837	300	233	189	18.5	639	293	100	210	124	83
19 33 27	3.8	6.8	300	1099	300	233	189	18.5	969	440	100	210	124	111
19 41 17	5.0	9.3	75	755	300	233	189	18.5	565	286	100	210	124	78
19 42 17	5.0	9.3	150	934	300	261	205	18.5	667	302	100	210	140	113
19 43 17	5.0	9.3	300	1099	300	233	189	18.5	969	440	100	210	124	116
19 41 27	6.9	12.4	75	755	300	233	189	18.5	565	286	100	210	124	78
19 42 27	6.9	12.4	150	934	300	261	205	18.5	667	302	100	210	140	123
19 43 27	6.9	12.4	300	1288	300	261	205	18.5	987	455	100	210	140	171
19 51 17	9.2	16.2	75	755	300	233	189	18.5	577	286	100	210	124	82
19 52 17	9.2	16.2	150	934	300	261	205	18.5	668	302	100	210	140	128
19 53 17	9.2	16.2	300	1288	300	261	205	18.5	987	455	100	210	140	171
19 51 27	11.9	21.9	75	812	300	261	205	18.5	581	290	100	210	140	107
19 52 27	11.9	21.9	150	1055	400	276	220	22.5	713	315	120	280	150	176
19 53 27	11.9	21.9	300	1426	400	276	220	22.5	1016	460	120	280	150	231
19 61 17	16.15	29.9	75	878	300	261	205	18.5	607	315	100	210	140	127
19 62 17	16.15	29.9	150	1140	400	291	233	22.5	718	333	120	280	163	208
19 63 17	16.15	29.9	300	1592	400	291	233	22.5	1021	467	120	280	163	282
19 61 27	22.1	40.5	75	878	300	261	205	18.5	607	315	100	210	140	129
19 62 27	22.1	40.5	150	1302	400	278	220	22.5	717	335	120	280	150	211
19 63 27	22.1	40.5	300	1720	400	302	240	22.5	1041	472	120	280	170	354
19 71 17	29.8	47.0	75	976	400	276	220	22.5	655	340	120	280	150	176
19 72 17	29.8	47.0	150	1446	400	291	233	22.5	728	343	120	280	163	251
19 73 17	29.8	47.0	300	1720	380	302	240	22.5	1041	472	120	260	170	368
19 71 27	35.0	60.0	75	1072	398	291	233	22.5	672	362	120	278	163	208
19 72 27	35.0	60.0	150	1570	400	302	240	22.5	757	370	120	280	170	316
19 73 27	35.0	60.0	300	1935	400	362	300	22.5	1111	513	120	280	230	524
19 81 17	44.2	80.0	75	1251	400	302	240	22.5	744	390	120	280	170	290
19 82 17	44.2	80.0	150	1805	400	362	300	22.5	829	413	120	280	230	515
19 83 17	44.2	80.0	300	1965	400	347	285	22.5	1186	547	120	280	215	740
19 91 17	59.0	100.0	75	1520	400	302	240	22.5	739	385	120	280	170	336
19 92 17	59.0	100.0	150	1805	400	362	300	22.5	829	413	120	280	230	516
19 93 17	59.0	100.0	300	1965	400	347	285	22.5	1186	547	120	280	215	767

① Dimension E in blocking position right at top – in other blocking positions E shortens accordingly and allows adjustment of + 60mm.

② Type 19 .. .7 is fitted with a load plate with PTFE slide plate as standard. If needed, this type can also be supplied with a high temperature slide plate, type 19 .. .6 (see table below).

③ Under certain circumstances the support bracket with the height K can be dispensed with. It should however be ensured that the load adjustment screws are accessible.

type 19* with slide plate		øL ₁
up to 180°C	up to 350°C	
19 D. .7	19 D. .6	40
19 1. .7	19 1. .6	40
19 2. .7	19 2. .6	40
19 3. .7	19 3. .6	65
19 4. .7	19 4. .6	65
19 5. .7	19 5. .6	65
19 6. .7	19 6. .6	110
19 7. .7	19 7. .6	150
19 8. .7	19 8. .6	150
19 9. .7	19 9. .6	150

* friction value of the slide plates see table p. 7.11

Max. permissible stresses:

- Emergency (HZ) at 80°C = calibration load x 1.33
- Faulted condition (HS) at 150°C = calibration load x 1.66.
- Max. blocking load at 80°C = calibration load x 1.5.

Order details: constant support type 19, marking:, calibration load: ...kN, travel: ...mm up/down, blocking position (as required): ...mm